

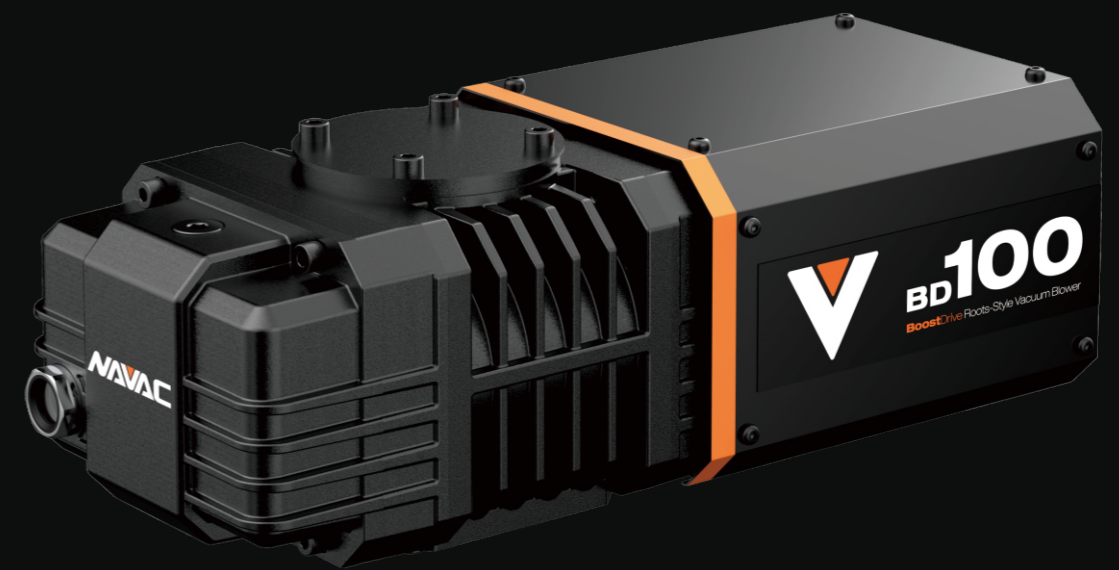

Empowering you to work smarter

BoostDrive Vacuum Pump Operating Manual



NAVAC Inc.
www.nava vacuum.com
Tel/Fax: +1 877 MY-NAVAC
877 696 2822
MADE IN PRC



Failure to follow warnings could
result in death or serious injury.

**SAVE THIS MANUAL
FOR FUTURE REFERENCE**

Contents

1. Use information	1
2. Attentions	2
3. Reception and Storage	4
4. Description	5
4.1 Characteristics of BD	5
4.2 Application	5
4.3 Function	6
5. Technical Parameters	7
5.1 Technical parameters Table	7
6. Installation & Wiring	8
6.1 Dimensions	8
6.2 Transportation	11
6.3 Installation	11
6.4 Power Supply & Rotation Direction	12
6.5 System Wiring	13
7. Operation	14
8. Maintenance	15
8.1 Daily Maintenance Method	15
8.1.1 Oil Change	16
8.2 Daily Maintenance Schedule	16
9. Troubleshooting	17
10. Warranty	19
11. Supplied Equipment	19
12. Main Parts of BD Roots Pump	20
12.1 Breakdown Drawing of BD100 Pump	20
12.2 Breakdown Drawing of BD600 Pump	22
12.3 List of Quick-wear Parts for BD Series Roots Pump	24

Use Information

Thanks for choosing NAVAC vacuum pump of high reliability (Hereinafter referred to as "the Pump / the Product").

Please check carefully whether the product received is the same as you ordered and the accessories, spare parts & operating manual are attached as well. Please also check if there's any damage occurred during transportation. If anything needed, contact the local distributor or our sales team.

In order to maintain a stable performance level of the pump, read this operating manual carefully to fully understand the safety instructions, technical data as well as operating procedures before installation, operation, repair and maintenance of the pump.

Warning

Failure to observe the terms could result in serious personal injury.

Notice

Failure to observe the terms could result in damage to the pump.



This warning label indicates that there may be a risk of electric shock. Cut off the power supply first in the process of electrical connection, repair and maintenance. Make sure the cover of the junction box is installed before running.



This warning label indicates high temperature hazard. Do not touch the pump when the pump is in operation.

Notice

Read the operating manual carefully and follow the operating procedures. We reserve the right to modify the design and technical data of the pump without notice which may have discrepancies in the manual. Add vacuum oil as requested before starting the new pump.

Attention

For personal safety, please read the following hints carefully before installation, operation, repair and maintenance.

Warning

- 1). Ensure effective grounding of the product and connect it to a motor protection switch of the rated value before startup.
- 2). The power supply connection must be operated by certified electricians under technical standards for electrical equipment and wiring regulations.
- 3). Keep the exhaust port unobstructed before running the product. Do not block or restrict airflow at the exhaust port.
- 4). When checking or repairing the pump, the power supply must be cut off before operation. This will avoid personal injury or death caused by electric shock or sudden startup of the pump.

- 5). Do not pump toxic, corrosive, inflammable or explosive gases.
- 6). Avoid using the pump near explosives and inflammable materials to prevent explosion or fire hazards.
- 7). Do not touch the motor and pump to avoid burns during long-term operation or when the pump has just stopped running for the surface temperature is still high.

! Notice

- 1). The pump's ambient temperature range is 5-40°C.
- 2). Do not place obstacles around the motor that prevent ventilation to avoid burns or fires, etc., caused by abnormal temperature rise.
- 3). Use a power supply consistent with the product's marked power supply.
- 4). Check the oil level of the pump before operation. Do not operate the pump if oil is insufficient or absent to avoid pump failure.
- 5). Check for oil leakage to prevent operators from slipping due to leaked oil.
- 6). Dispose of waste oil and other parts according to relevant environmental protection regulations.
- 7). Install relevant accessories to pump gas with small amounts of dust or condensable gas.

Pump Storage

3.1 Pump Storage

The Pump must be stored at the following conditions to ensure its stable and reliable running:

■ Ambient environment of storage:

- 1) There's no corrosive, inflammable and explosive gas;
- 2) The Pump must be placed indoors;
- 3) Avoid direct sunlight;
- 4) Keep way from heat sources;
- 5) Be protected against dust;
- 6) Be free from condensation.

! Notice

Place the pump horizontally and protect it against impacts to prevent damage.

Product Overview

As a high-speed directly-connected vacuum pump with sealed motor, the Product has been designed with a leak-tight and compact structure and sleek appearance.

The Product is featured by well-designed structure, high safety and reliability, fast vacuuming, high ultimate vacuum degree, low noise, easy maintenance and no oil leakage.

The Product's cavity is mounted with one pair of double-blade rotors which can have reverse and high-speed rotation simultaneously, and the rotation of two rotors would inhale and exhaust air during operation; the Product can be used as booster pump. Under low pressure intensity, the gas module has longer Mean Free Path, so the gas will encounter higher resistance when passing the small gap, leading to high vacuum degree and compression ratio.

! Notice

The Product should not be used alone, but be in serial connection with the backing pump, as shown in Fig. 1:

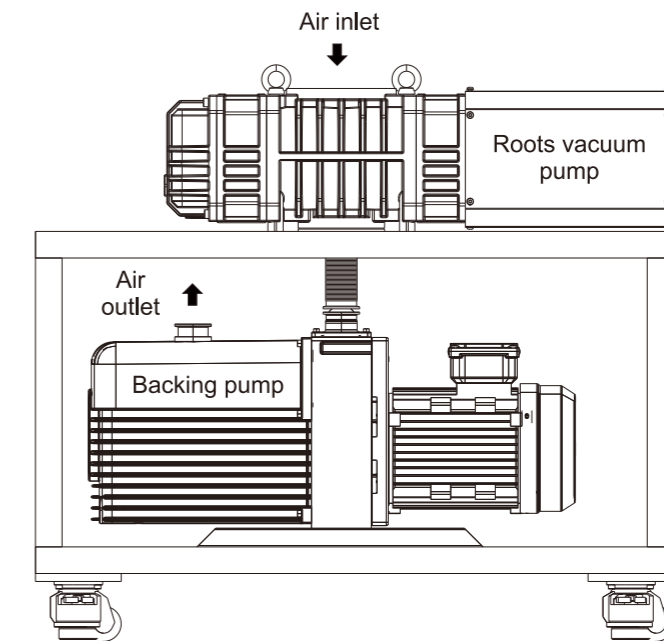

Fig. 1 Schematic Diagram of BD Series Roots Vacuum Pump

4.1 Characteristics of BD Pump

- The Pump's one pair of rotors are designed and processed by fully ensuring symmetry, and in compact structure and occupy a small area with the characteristics of high speed, small volume, light weight and low vibration.
- Based on fast startup, the Product can reach the ultimate vacuum degree in a short period, with no compression in pump cavity, in order to eliminate condensable gas;
- Certain clearance is reserved between rotors and between rotor and pump cavity, to avoid contact and friction, and ensure low power consumption and good energy conservation;
- As no oil lubricating is required in pump cavity, the contamination of the vacuum system caused by oil steam no longer exists and the pump becomes insensitive to fine dust.

- Featured by stable vacuuming speed within the pressure intensity of $1.3 \times 10^{-3} \sim 1.3 \text{Pa}$, the Pump can quickly exhaust any suddenly released gas, eliminate the weaknesses of oil-sealed vacuum pump and diffusion pump. So, it is suggested to use it as a booster pump; Fitted with sealed motor structure on the basis of static seal, the Product can prevent oil leakage of shaft seal;
- Different backing pumps can be selected based on the Product's characteristics and use conditions It can be matched with DD/UD series vacuum pumps when pumping large amount of vapor, small amount of dust and slightly corrosive gas under a relatively low vacuum degree. We can design different roots pump vacuum units based on the requirements and use conditions of vacuum equipment of users.

4.2 Scope of Application

As a kind of basic vacuum equipment in the field of vacuum application, the Product is widely applied in the industries such as chemistry, food, medicine, smelting, coating and refrigerating.

4.3 Structural principles

The operating principle of the pump is shown in Fig. 2:

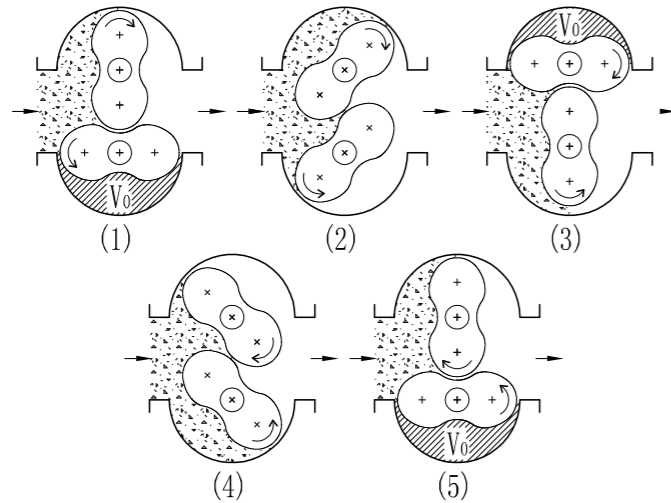

Fig. 2 Schematic Diagram of Working Principle

When the pump works, the gas in the pumped container enters into the pump chamber, the mixed gas in V_0 is just enclosed without compression and expansion, with the rotation of the rotor, the top of the rotor reaches the edge of the exhaust port, due to the pressure difference, the gas at the exhaust port of the pump will diffuse into the space to be pumped away by the backing pump. With the continuous operation of the rotor, more gases are sent to the exhaust port to be pumped away by the backing pump, above is the volumetric action principle of the pump; because the pump works in the case of very low inlet pressure, and the rotor speed of the pump is as high as 2,840r/min, and the linear velocity of the rotor surface is close to the speed of the molecular thermal movement, the gases colliding with the rotor are carried by the rotor to the exhaust port where the pressure is high, and then pumped away by the backing pump, this is the molecular action principle of the pump. This is the molecular action principle of the pump; the combined effect of the two principles prompts this type of pump to have a large and smooth pumping speed in the interval of $1.3 \times 10^{-3} \sim 1.3 \text{Pa}$.

Technical Parameters

5.1 The technical parameters are as shown in Table 1

Model		BD100	BD600
Pumping rate(m^3/h)	m^3/h	190	720
	Pa	3.0×10^{-2}	3.0×10^{-2}
Ultimate pressure	mbar	3.0×10^{-4}	3.0×10^{-4}
	Torr	2.2×10^{-4}	2.2×10^{-4}
Max. allowed differential pressure	Pa	6.6×10^3	6.6×10^3
Power supply	/	220~230V/60Hz	220~230V/60Hz
Power	kW	0.37	1.5
Rated speed(60 Hz)	rpm	3460	3460
Oil viscosity	/	100	100
Oil capacity	L	0.5 (gear end)	0.5 (gear end)
			0.25 (motor end)
Air inlet	mm	DN50	DN100
Air outlet	mm	DN50	DN63
Ambient temperature	$^{\circ}\text{C}$	5-40	5-40
Noise	dB	≤ 62	≤ 63
Weight	lbs	50.7	218.2
Dimensions (L*W*H)	in	19.4x8.3x6.3	30.7x11.2x8.5

Table 1 Technical Parameters

Installation & Wiring

6.1 Installation Dimensions

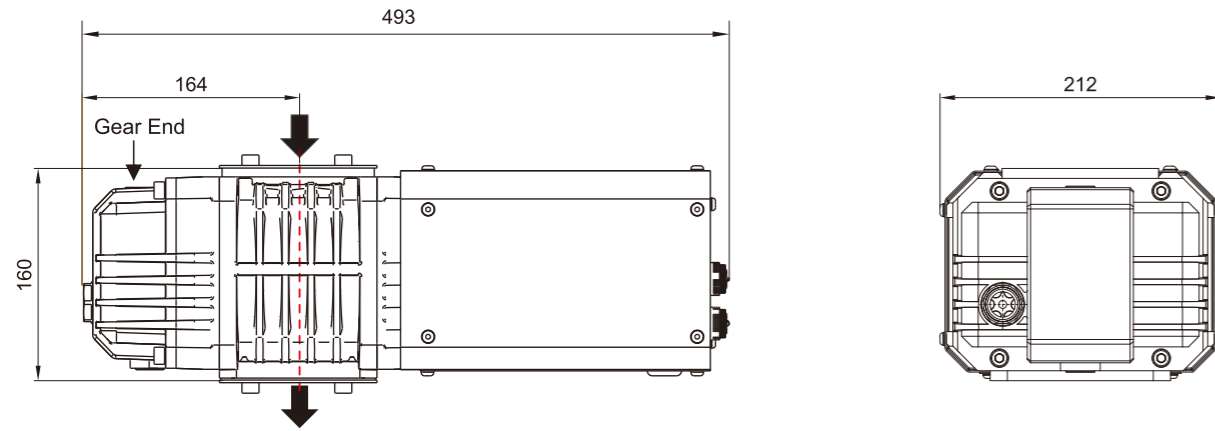

Unit: mm

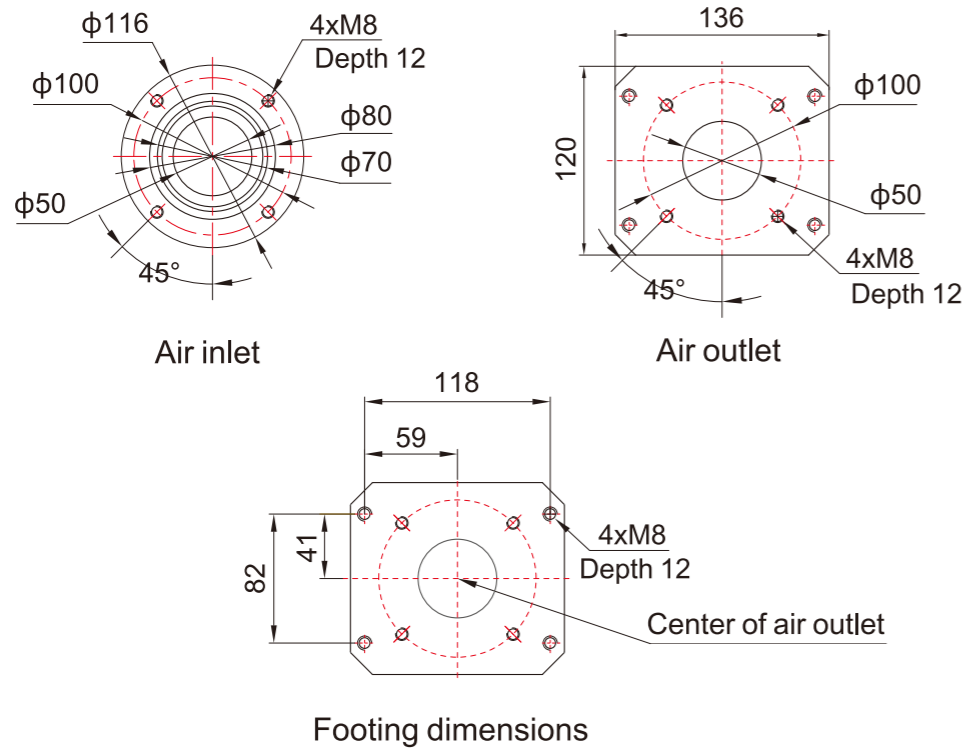
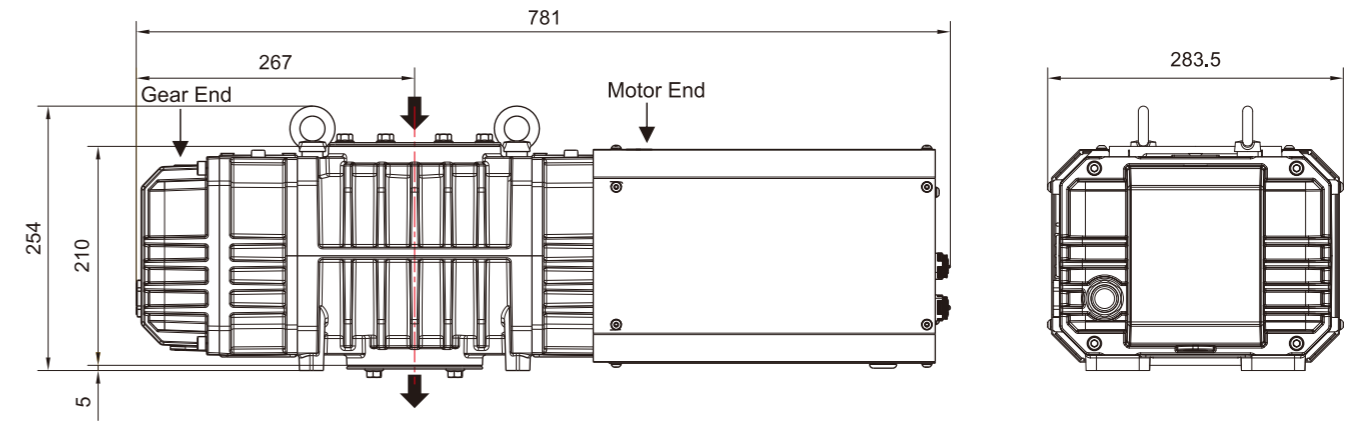

Fig. 3 Dimension Drawing of BD100 Roots Pump



Unit: mm

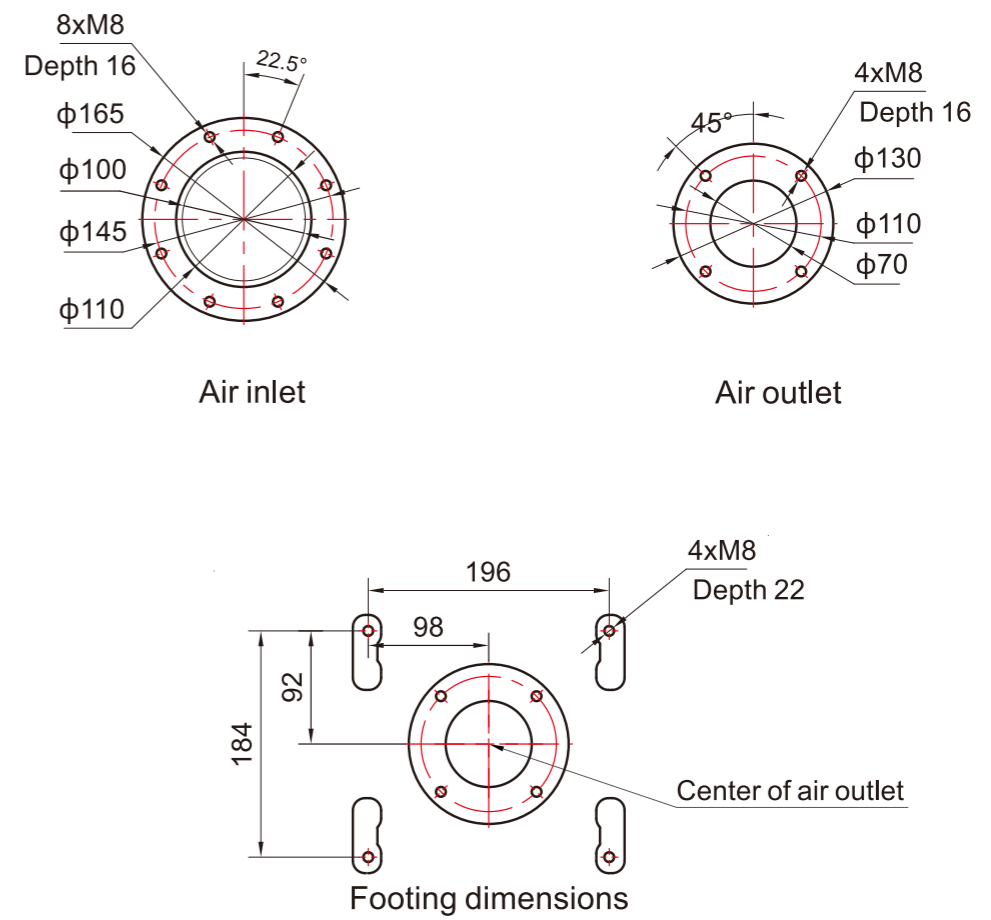

Fig. 4 Dimension Drawing of BD600 Roots Pump

6.2 Handling

Please handle the Product with care, for any negligence may lead to damages of the Product.

Warning

- 1). Do not relocate the pump until it has stopped and powered off.
- 2). Check for oil leakage to prevent operators from slipping due to leaked oil.

Notice

The pump must be hoisted through the lifting bolts on it.

6.3 Installation

Notice

Install the pump in well-ventilated places where installation, maintenance, dismantling, and wiring can be easily done.

Warning

- 1). Avoid using the pump near explosives and inflammable materials to prevent explosion or fire hazards.
- 2). Keep obstacles away from the motor to prevent scalding or fire hazards due to abnormal temperature rise.

Notice

- 1). Install the pump in clean places. Use anti-dust devices as required on the air inlet.
- 2). The pump footing can be placed horizontally on the ground or connected through bolts when connecting to the vacuum system.
- 3). Install the pump stably and firmly within a horizontal degree of 10° to prevent pump vibration, increased noise, and damage.
- 4). Use the pump in places with ambient temperatures of 5-40°C and moisture not exceeding 85%. Increase the ambient temperature properly if it is below 5°C to prevent oil viscosity increase and startup difficulty.

6.4 Power Supply & Rotation Direction

Warning

Use a power supply consistent with the product's marked power supply. Certified electricians should connect the power supply correctly according to technical standards and wiring regulations. Measure the phase sequence of the incoming power supply clockwise for 3-phase motors and connect them accordingly.

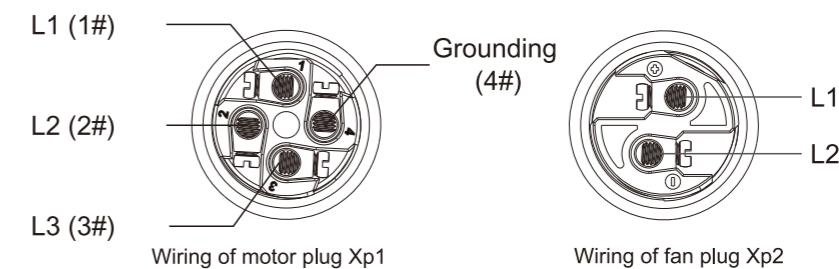

Fig. 5 Wiring of 3-phase Motor

Definition of 3-phase power cable:

1. Phase A line: Also known as Line L1 or Line U;
2. Phase B line: Also known as Line L2 or Line V;
3. Phase C line: Also known as Line L3 or Line W;
4. Grounding line: Also known as Line PE.

When the Product is used for the very first time, make sure to disconnect the air inlet and outlet pipe, open the air inlet of roots pump, connect the Product's power supply according to sequence in Fig. 5, conduct short-term inching of the Pump's starting power supply, check if rotor blade direction is consistent with the arrow direction on the Pump; if the direction is inconsistent, cut off power supply immediately, exchange two phase wires (any 2 wires of U, V and W) to correct the rotation direction of motor.

- It can be matched with a frequency converter to better improve pumping rate and overpressure protection capability;
- The frequency converter is recommended to specifically use NAVAC frequency converter, which can achieve the most reliable performance;
- When matching with inverters of different manufacturers, it is necessary to confirm with NAVAC.

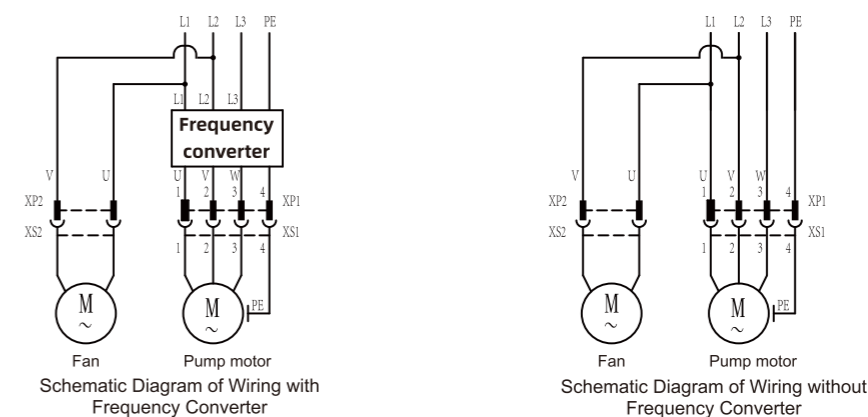

Fig. 6 Schematic Diagram of Wiring

**Notice**

Wiring must follow the sequence shown in Fig. 6. Incorrect wiring may lead to electrical safety accidents.

6.5 System Wiring

The BD series pump is connected to vacuum system through flange, the size of which should be confirmed carefully. The Product must be fitted with a vacuum fore pump as the backing pump instead of being used independently. If oil-sealed mechanical vacuum pump is used as backing pump, it should not be used for pumping explosive gas that has high oxygen content, has corrosion to ferrous metal, chemical reaction to vacuum oil and contains dust; otherwise, the service life of backing pump can be shortened.

Wiring of vacuum system:

- It is recommended to install a hose (metal corrugated pipe) to the connection pipeline between the Product and the backing pump; the pipe should be as short as possible, have few joints and bends; the pipe diameter should not be less than that of pump;
- The pipe that connects the Product and vacuum system should be as short as possible;
- The pipe that connects the Product and vacuum system should have consistent diameter with the air inlet. Inspect the filter screen of air inlet regularly and keep it clean;
- The connection pipe of pump exhaust port should have a consistent diameter with the exhaust port;
- Carry out leakage inspection to the position where pipe and flange are connected. Good vacuum airtightness is crucial for the Product to reach the ultimate pressure;
- It is recommended to install vacuum valve to the Product's air inlet pipe, in order to maintain vacuum state of pump cavity when the pump is stopped.

**Warning**

Do not use blocked or narrow exhaust pipes. Ensure baffles or similar block devices are open to prevent exhaust pipe blockage due to sediments before starting the product.

Initial Startup & Functioning**7.1 Functioning**

Inspection prior to functioning:

- The exhaust port of the pump must be clear and the pump must not be started with the exhaust port blocked;
- Check if the motor revolving direction conforms to the requirements;
- Check if the motor is grounded effectively;
- Check if motor power supply is consistent with the voltage and frequency on nameplate;

Functioning without frequency converter:

- Start the backing pump;
- Open the Product's air inlet valve;
- The Product's allowed starting pressure, which depends on the proportion between the roots valve and backing valve, can be calculated according to the following formula:

$$\text{Entrance pressure } P_{\text{entrance}} \text{ at startup of pumps} \leq \frac{P_{\text{max.}} (\text{max. allowed differential pressure of pump})}{\text{Pumping rate/pumping rate of backing pump} - 1}$$

$$\text{Example : BD100 / DD30, } P_{\text{in}} \leq \frac{4000}{160/30-1} = 923 \text{ Pa}$$

- Check if the Product has stable running and rotor is free from collision sound; otherwise, stop the Product immediately for inspection;
- For any fault, such as local temperature rise, sudden current change and irregular noise during functioning, stop the Product immediately for inspection.

Functioning with frequency converter:

- The roots pump can be started at the atmosphere, but the startup and acceleration period vary along with the size of container. The frequency converter can improve the speed and bring certain overload protection capability.
- Start the backing pump;
- Open the inlet valve of the pump;
- Check if the Product has stable running and rotor is free from collision sound; otherwise, stop the Product immediately for inspection;
- For any fault, such as local temperature rise, sudden current change and irregular noise during functioning, stop the Product immediately for inspection.

Stop running:

- Close the air inlet valve on air inlet pipe firstly;
- Shut down the roots vacuum pump;
- When the roots vacuum pump is stopped, shut down the backing pump.

Long-term idling of pump:

- Close the air inlet valve on air inlet pipe firstly;
- Shut down the roots vacuum pump;
- When the roots vacuum pump is stopped, shut down the backing pump.
- Disconnect the water and electric circuit; disconnect the air inlet pipe if necessary, cover the air inlet with cover plate against dust and moisture.

Inspection & Maintenance

Warning

- 1). Cut off power supply before inspection. Do not connect power supply during inspection to prevent personal injury.
- 2). Ensure the product is completely cooled before inspection to prevent burns, as the product remains hot after stopping.

8.1 Daily Maintenance Method

Warning

- 1). For a better performance and life, please pay often attention to the lubrication state of all parts and refuel the lubricating oil in time. Under any circumstances like deterioration, oil turbidity, please replace the oil in time and make sure that all parts are sealed.

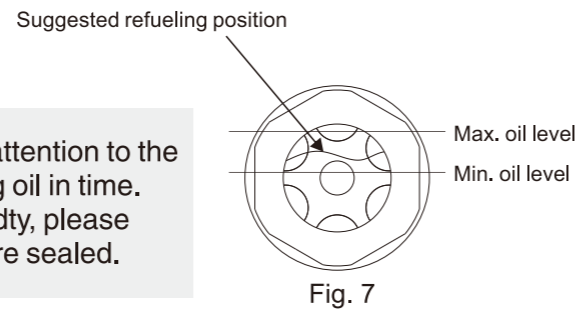

Fig. 7

- 2). While working, the oil level should stay within Max~ Min. Refuel the lubricating oil when it's lower than Min; Drain the excessive oil when it's above Max.

Notice

Observe the pump oil color, which should be clean and transparent. Replace oil if it becomes dark or turbid.

Warning

Confirm hazard properties and follow relevant safety regulations if hazardous substances exist. Treat pollution before running the product if potential hazards persist.

Notice

Do not replace oil while the product is hot. Ensure the product is powered off and the motor is not hot before replacing the oil.

8.1.1 Oil Replacement

- Open the oil drain plug, drain the used oil into a proper container, then fasten the oil drain plug when oil flow stops;
- Fasten the oil drain plug (check the O-ring and replace it in case of damage);
- Open the oil drain plug, inject fresh oil, keep the oil level within the Max ~ Min range of oil indicator, or at the upper level of oil cup; then fasten the oil drain plug or close the seal cover.

8.2 Daily Maintenance Schedule

Inspection Contents	Operation & Test	Maintenance Frequency	Remarks
Inspection of lubricating oil level	Do visual inspection to the oil level	For every 3 days	Refuel when the oil level drops
Inspection of lubricating oil color	Visually check for abnormal pump oil color at the oil mirror window.	For every 3 days	The oil should be clean and transparent. If oil becomes dark, please replace it by referring to 8.1.1
Inspection of pump sound	Check if there's abnormal sound	For every 3 days	For any abnormal sound or high noise, please refer to IX Fault Analysis
Inspection of pump vibration	Check if there's excessive vibration	For every 3 days	Check if pump footing and foundation bolts are loose
Inspection of pump temperature	Measure the pump temperature with a thermometer	Weekly	Check if the fan of pump and motor has sediments; if so, please clean it.
Inspection of air inlet filter screen	Check if there are foreign matters	Trimonthly	Remove the foreign matters and dry it with compressed air
First oil replacement	Do statistics of running period	500h after the first running	Refer to 8.1.1 for the oil replacement method

Table 2

Fault Analysis

Fault	Cause	Troubleshooting
Pump start failure	1. Power supply is disconnected	1. Inspect the power supply, switch and wiring conditions
	2. Input power supply has voltage error	2. Make sure voltage fluctuation is within the range of $\pm 10\%$ of rated voltage
	3. Motor failure	3. Replace the motor
	4. The ambient temperature is too low	4. Increase the ambient temperature
	5. The pump is blocked by a foreign matter	5. Repair the pump
	6. The pump body is rusted due to long-term idling, inhalation of water and organic solvents	6. Repair the pump
	7. The internal parts of pump are damaged	7. Repair the pump
The pump fails to reach ultimate pressure	1. The vacuum system configuration is improper, or the pump is too small	1. Reselect the pump
	2. The connected container or connection pipe has air leakage	2. Inspect and eliminate the air leakage
	3. Measurement method or gauge is improper	3. Please use the proper measurement method or gauge; measure the vacuum degree directly at the air inlet of pump
	4. Vacuum gauge is inaccurate or improper	4. Select proper vacuum gauge
Pumping is too slow	1. The air inlet pipe is blocked	1. Clean the air inlet pipe
	2. The air inlet pipe is too narrow or too long	2. Please use short and thick air inlet pipe
	3. Air exhaust pipe is unsmooth	3. Keep the air exhaust pipe smooth
	4. Air exhaust filter screen is blocked	4. Clean or replace the air exhaust filter screen

Fault	Cause	Troubleshooting
Pump has abnormal sound	1. Input power voltage is abnormal	1. Inspect the power supply, switch and wiring conditions
	2. Motor error	2. Make sure voltage fluctuation is within the range of $\pm 10\%$ of rated voltage
	3. The pump has foreign matters	3. Dismantle the pump for repairing and removing the foreign matters
	4. The oil level of pump is too low	4. Fill oil to proper level
	5. The internal parts of pump are damaged	5. Dismantle, repair and replace the parts
	6. The bearing has fatigue damage	6. Replace the bearing
	7. Rotor clearance is changed	7. Remove the gear for cleaning, reinstall it and adjust the clearance
	8. Gear has fatigue damage	8. Replace the gear
Pump temperature is too high	1. Pressure intensity between air inlet/outlet has high difference	1. Inspect the pressure of vacuum system
	2. Oil level of pump is too low	2. Fill oil as specified
	3. Temperature of pumped gas is too high	3. Install a cold trap at the air inlet
	4. Poor ventilation	4. Improve the ventilation environment
	5. The ambient temperature is too high	5. Lower the ambient temperature
	6. Friction resistance is too high; the bearing or oil is polluted	6. Clean the bearing or replace the oil

Table 3

Warranty

The Product enjoys 1-year warranty since the date of procurement. For any fault of the Product within the warranty when used at normal conditions, the Company will offer maintenance services for free. The Company will offer paid services in any of the following cases:

- (1) The fault caused by natural disasters or human factors;
- (2) The fault caused by special operation environment;
- (3) Damage of sealing elements and quick-wear parts (see Table 2, 3 and 4);
- (4) The fault caused by misoperation or misuse according to identification of our technicians;
- (5) If the pump is sent back to us for repair, it must be stated whether or not the pump is contaminated or does not contain substances harmful to persons; if the pump is contaminated, state exactly what kind of contaminants are contained, and if there is no statement of contamination, we will return the pump to the shipper at the address.

Supplied Equipment

11.1 Standard Equipment

The supplied equipment includes standard pump, air inlet dust cover, sealing pads, motor plug, fan plug, excluding switch and power cable.

11.2 Accessories

Please use the attached accessories to keep the Product stable. Please provide the model of pump when placing an order.

1. Inlet vacuum filter
2. Inlet/outlet interface
3. Frequency converter
4. Vacuum gauge
5. Corrugated pipe
6. Other accessories

Note: The accessories are optional parts. For any demand, please contact us.

Main Parts of BD Roots Pump

12.1 The breakdown drawing of BD100 pump is as shown in Fig. 8-9:

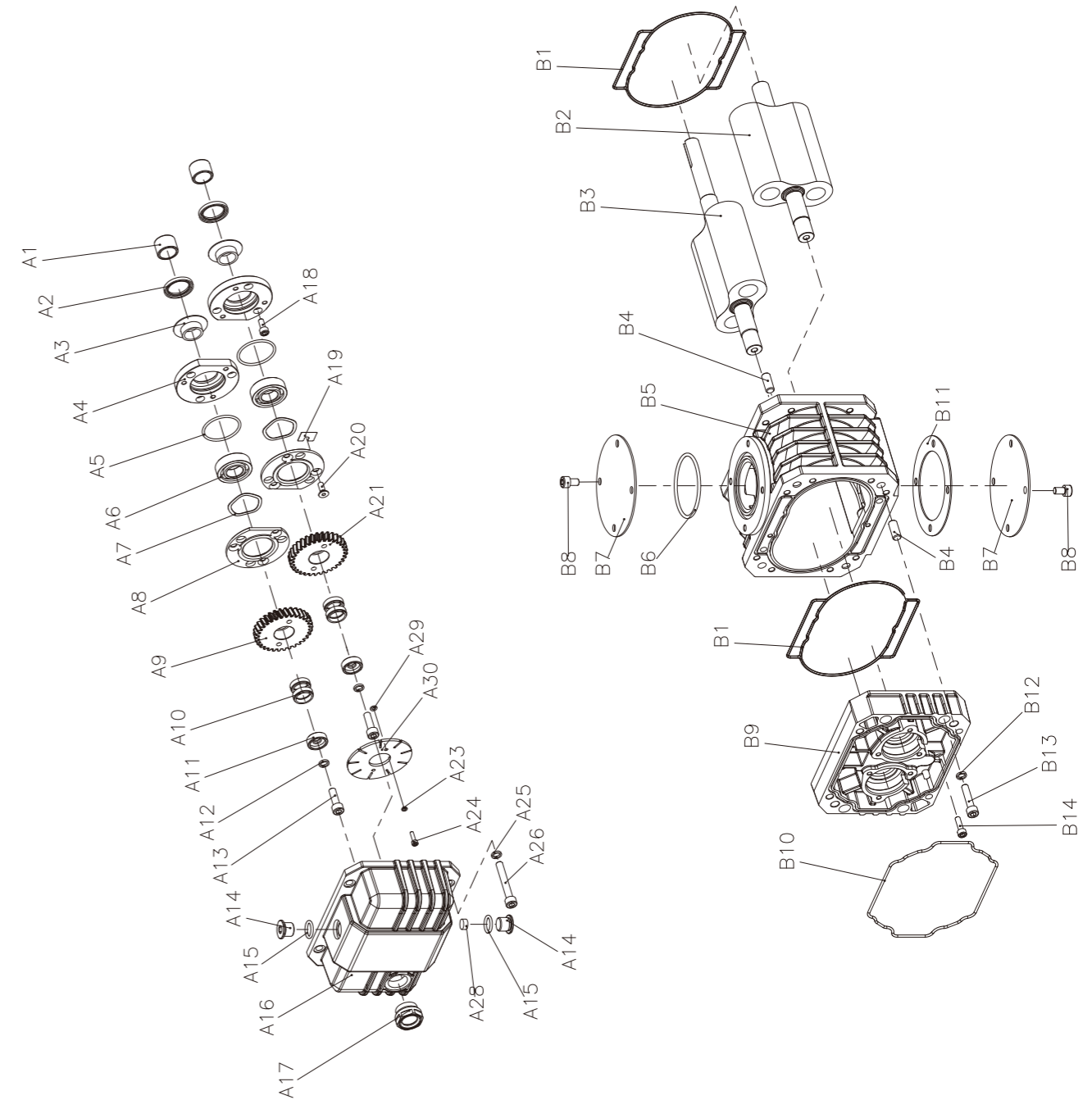

Fig. 8

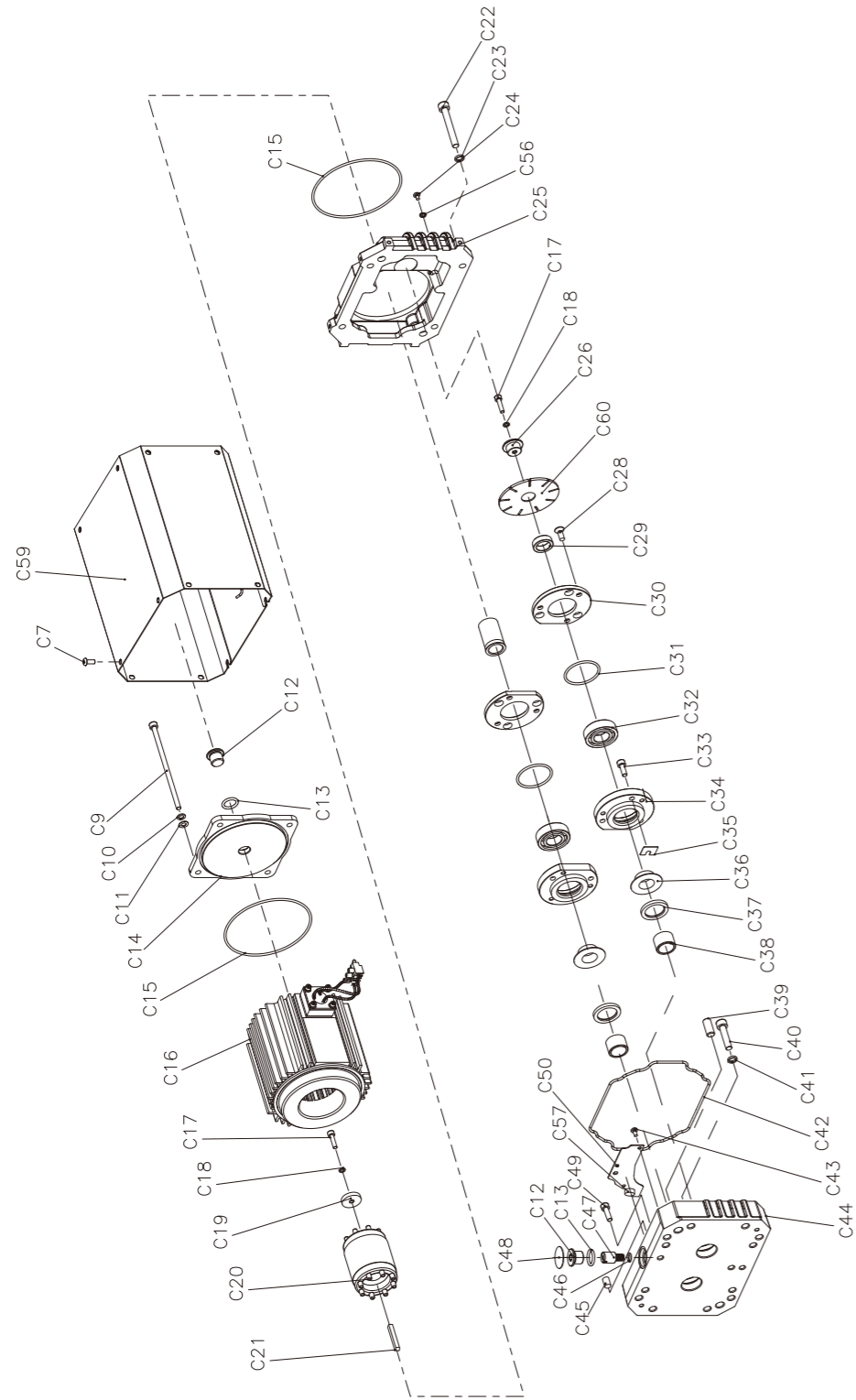

Fig. 9

12.2 The breakdown drawing of BD600 pump is as shown in Fig. 10-11:

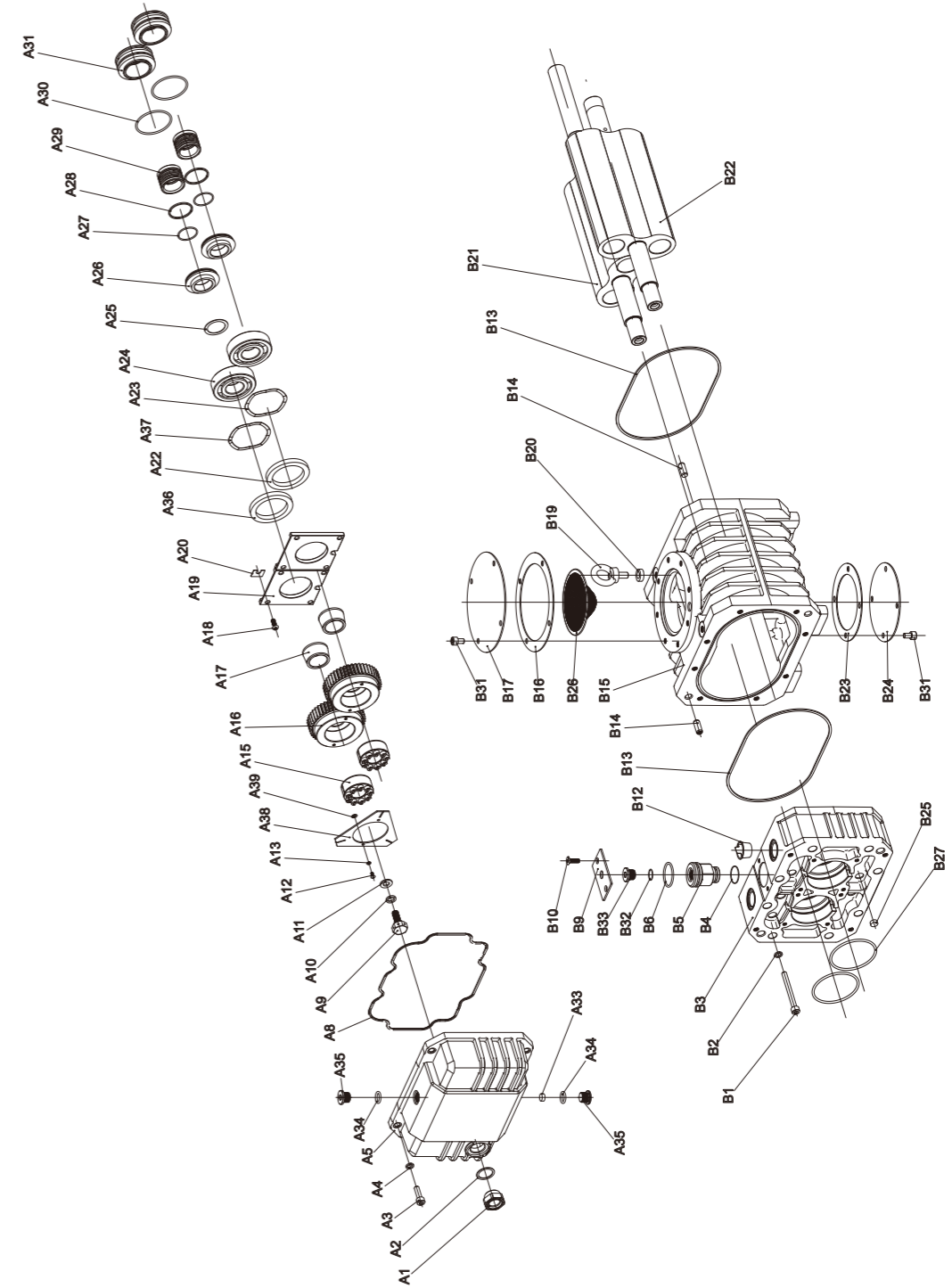

Fig. 10

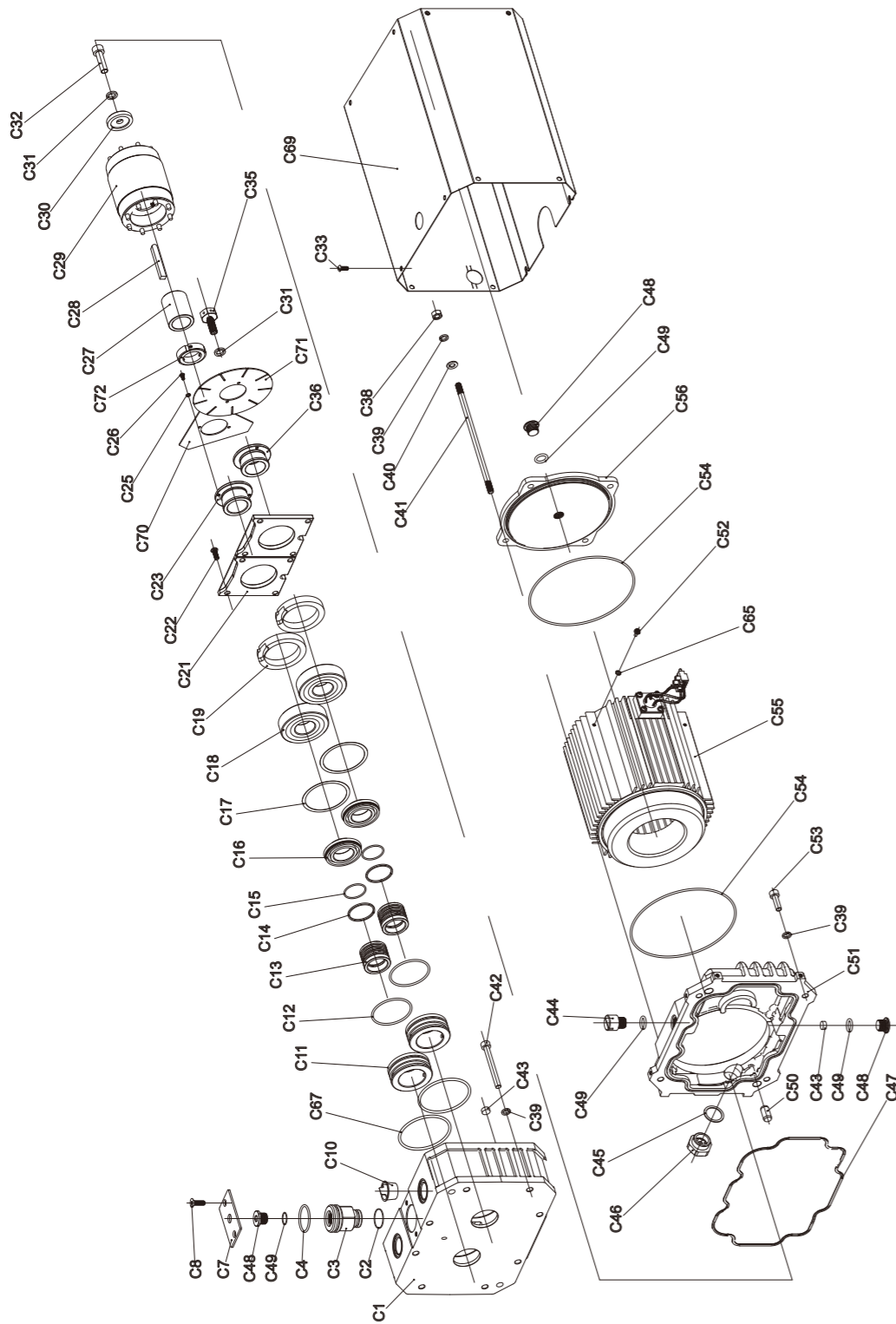

Fig .11

12.3 List of Quick-wear Parts for BD Series Roots Pump

S/N	Product Name	Material	Qty.
B6	O-ring Φ 69 (inner) *3.55	Fluororubber	1
A15	O-ring Φ 14 (inner) *3	Fluororubber	2

Table 4 List of Quick-wear Parts for BD100 Roots Pump

S/N	Product Name	Material	Qty.
A34/C49	O-ring Φ 14 (inner) *3	Fluororubber	4

Table 5 List of Quick-wear Parts for BD600 Roots Pump

Correct Disposal of this product:

This marking indicates that this product should not be disposed with other household wastes. To prevent possible harm to the environment or human health from uncontrolled waste disposal, please use the return and collection systems or contact the retailer where the product was purchased. They can take this product for environmental safe recycling.

